

PM 15.5



truck mounted cranes



Classic Series

DESCRIPTION TECHNICAL FEATURES

Efficiency, ability to perform any kind of job and user-friendliness are the main features of this series that completes the range of PM light duty cranes. It is a crane that can be used for various applications, given its loading capability and the several optional available.

STANDARD CONFIGURATION

MANUAL HYDRAULIC CONTROL

SLEWING BY RACK

MANUAL PULL-OUT OUTRIGGER BOOMS

SAFETY KIT FOR OUTRIGGERS

OPTIONAL

CONTROL VALVE BLOCK COMPENSATED PVG 32

RADIO REMOTE CONTROL MULTIFUNCTION

HOSE RACKS SUPPLEMENTARY

OIL TANK

OIL COOLER WITH BYPASS



Radio remote control multifunction



Oil cooler with bypass



Control valve block compensated pvg32

PM 15.5



truck mounted cranes

EQUIPMENTS SUMMARY

Equipments	Standard	Option
Slewing by rack	<input type="radio"/>	
Manual pull-out outrigger booms	<input type="radio"/>	
Hydraulic pull-out outrigger booms		<input type="radio"/>
Sequential extension booms' output	<input type="radio"/>	
Oil cooler		<input type="radio"/>
Proportional hydraulic control valve block		<input type="radio"/>
Multifunction radio control		<input type="radio"/>
Hydraulic winch on crane		<input type="radio"/>
Hose racks supplementary		<input type="radio"/>
Manual extension		<input type="radio"/>
Stability Power System*		<input type="radio"/>
Safety Kit for outriggers*		<input type="radio"/>
4 metres alarm sensor with control panel in cab *		<input type="radio"/>
Ball-joint outrigger plates *		<input type="radio"/>
LMU Device: control system for manual extensions		<input type="radio"/>
Slewing limiter		<input type="radio"/>
LC configuration		<input type="radio"/>
Top seat		<input type="radio"/>
Top Stand control		<input type="radio"/>
Oil tank		<input type="radio"/>

*compulsory for CE area

CERTIFICATION



In accordance to the EU safety standards



3 years of warranty on the structural parts



Quality Certificate UNI EN ISO 9001:2008



In accordance to H1-B3 standard



Certified painting system

PM 15.5



truck mounted cranes

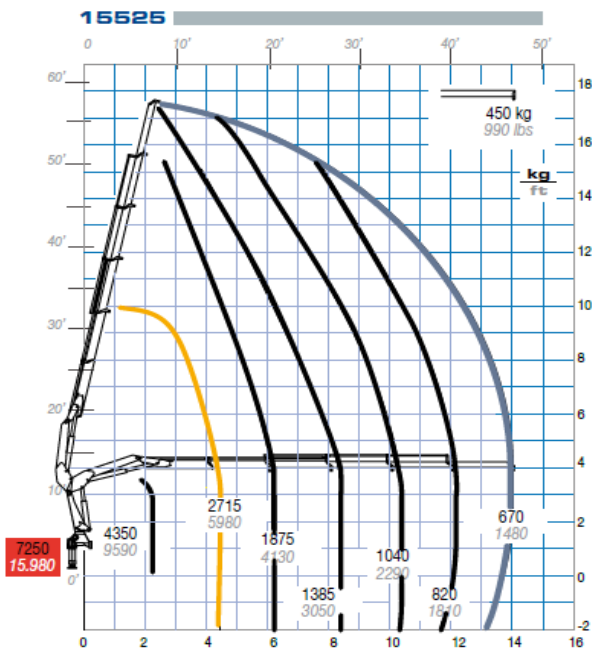

TECHNICAL INFORMATION PM 15525



Only with LC version



Max. capacity from horizontal to vertical



Max. nominal capacity with fixed hook

TRUCKING CRANE COMBINATION

Maximum lifting moment	tm 12,9 ft lbs 93280
Hydraulic outreach	
Horizontal	m 14,40 ft 47'3"
Vertical	m 17,70 ft 58'1"
Maximum reach with manual extension	
horizontal	m 16,15 ft 52'12"
vertical	m 19,35 ft 63'6"
Hydraulic system	
Max. oil flow	l/min 30 gals/min 8
Max. pressure	Mpa 30 Psi 4350
Oil tank capacity	l 88 gals 23
Slewing system	
Slewing angle	400°
Slewing moment	kNm 16 ft lbs 11800
Max. working heel	%(°) 8,7(5)
Standard crane weight	
Empty oil tank	Kg 2180 lbs 4810
LC version	-

PTT/GVV	15.5	2STD	2 outriggers STD
15,0 TON	4		
18,0 TON	2 XL		
19,0 TON	2STD		
PTT/GVV	15.5	2 XL	2 outriggers XL
26,0 TON	2STD		
32,0 TON	2STD		
PTT: G.V.W.		4	4 outriggers

Technical data can be revised without prior notice.

PM 15.5



truck mounted cranes

DIMENSIONS Standard Crane

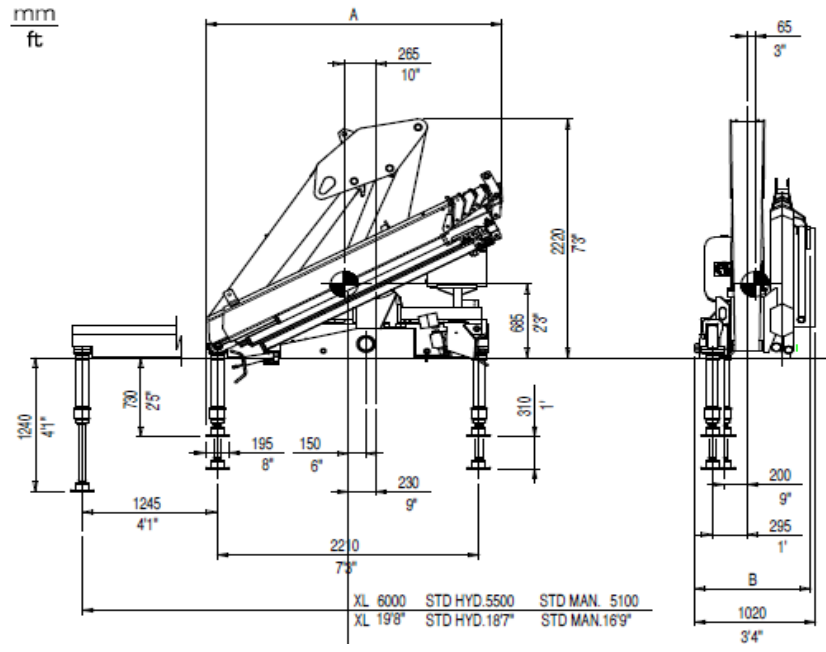

	15525
A (mm) (ft)	2500 8'2"
B(mm) (ft)	980 3'3"

ACCESSORIES



Variable pump



PTO

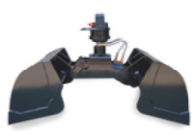

Clamshell Buckets



Cross Beams for car lifting



Pallet forks



Augers



Swivel Hooks



Clamshell Buckets



Log Grabs



Brick Grabs



Supplementary Outrigger



Hydraulic Grapples



Operator Baskets and Self-Levelling Platforms